

**NOTES**

1. WHEN THIS DRAWING IS USED AS AN ORDER SUBMITTAL, IT MUST BE SIGNED, AND AN ORDER SUBMITTAL FORM MUST BE INCLUDED.
2. 30 YEAR WARRANTY COVERAGE - SEE INTERCEPTOR LIMITED WARRANTY FOR DETAILS
3. OPTIONAL ACCESSORIES (LEVEL ALARMS, EXTENSION RISERS, STREET BOXES) ARE ALSO AVAILABLE.

**DESIGN PARAMETERS**

1. TANK SIZE: 4' DIA SINGLE-WALL, 48 1/2" O.D.
2. NOMINAL TANK CAPACITY: 1,800 GALLONS.
3. NOMINAL TANK WEIGHT: 1,700 LBS.
4. INVERT DIMENSION FROM TANK I.D.
5. CAPACITY AT FLOW LINE: 1500 GALLONS.
6. MAX OIL CAPACITY: 883 GALLONS.
7. MAX SOLIDS CAPACITY: 463 GALLONS.

**APPROVAL**

THE UNDERSIGNED ACKNOWLEDGES AND AGREES TO THE USE AND DESIGN PARAMETERS AS DETAILED ON THIS DRAWING AND IN THE ACCOMPANYING ORDER SUBMITTAL FORM AND HEREBY APPROVES FABRICATION.

SIGNATURE \_\_\_\_\_

PRINTED NAME \_\_\_\_\_ DATE \_\_\_\_\_

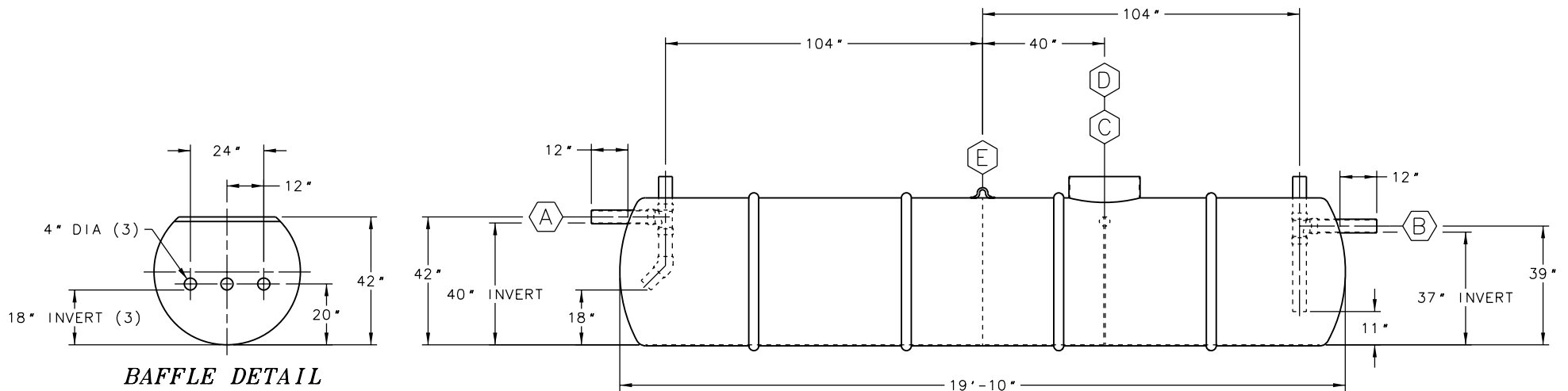

ITEM	QTY	DESCRIPTION
(A)	1	4"DIA SCH 40 PVC INLET PIPE WITH INTERNAL SANITARY TEE, PIPES & 45° ELBOW
(B)	1	4"DIA SCH 40 PVC OUTLET PIPE WITH INTERNAL SANITARY TEE & PIPES
(C)	1	RISER PIPE, 23 3/8" O.D., FOR 24"(NOMINAL) ACCESS OPENING
(D)	1	42" HIGH PLATE BAFFLE WITH 3-4"DIA HOLES (18" INVERT)
(E)	1	LIFTING LUG

**ZCL | XERXES®**

TITLE  
**MODEL 01-4-1500-SM  
 OIL INTERCEPTOR**

DATE 1-17 DR. NO. S11-967.00

INDUSTRY TYPE: M210 PLUMBING ENGINEERED SOLUTIONS